



QUOTATION REQUEST FORM

Phone: 1300 369 029

Email: enquiries@amplusgroup.com.au

Fax: 02 9609 2388

Name: Ph: Email:.....

Please sketch your requirements, where possible please include dimensions.

Nearest to Kerb Side Description

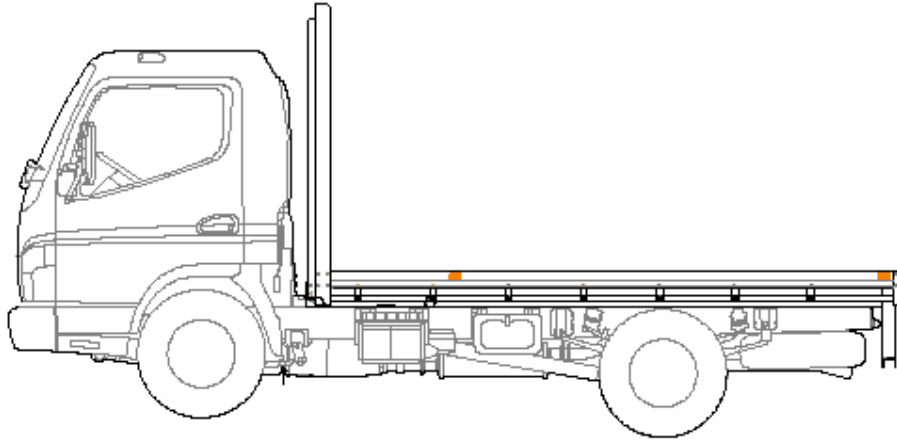

Offside Description

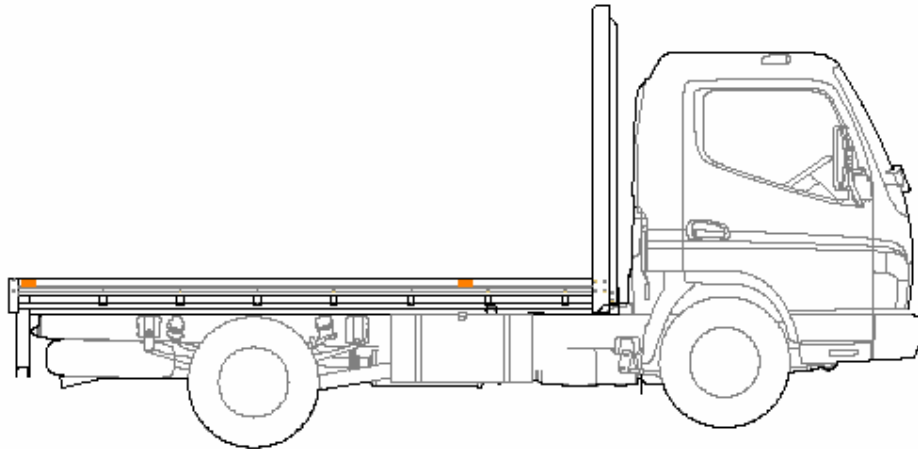

Plan View Description

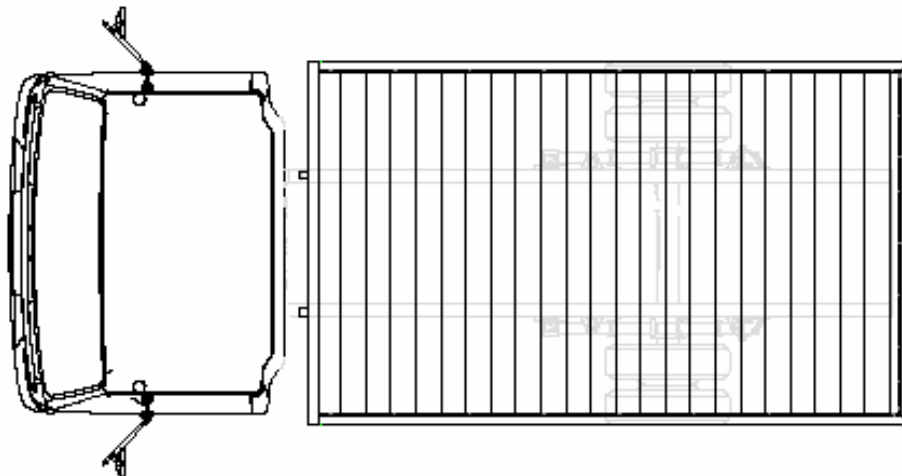



QUOTATION REQUEST FORM

Phone: 1300 369 029

Email: enquiries@amplusgroup.com.au

Fax: 02 9609 2388

Rear View Description

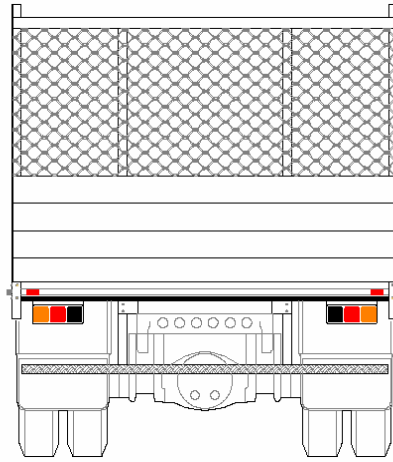

	<u>Y / N</u>	<u>Dimension / Details:</u>
Tray		
Headboard		
Drop sides / Split sides		
Rear Rack		
Cabinets:- - Door style - Shelving - Draws - Other		
Toolbox		
Equipment Drawer / Shovel Box		
Ladder Racks		
Work Lights		
Paint		
Crane		
Lyco Loader / Tail Gate		
Accessories:- - Tow Bar - Steps - Racks - Vice - Water Container - Reverse Sensor - Other		

Please fax this form to 02 9609 2388 for a quote or call us on 1300 369 029.